

FSALV

Fully Adjustable Operator Armchair System

FSALV	Fixed base flip up consoles
FSALVDS	Fixed base, $\pm 90^\circ$ seat and console swivel lockable every 10°
FSALVD	Rotating base, ball bearing

Construction:

The **FSALV** is an ultra compact, fully adjustable seating system that allows integration of seat and controls. The smart design makes this system ideal for small cabs and tight workspaces while offering an abundance of manual adjustments. The multi-adjustable control arms include integrated armrests and control pods along with the ability to have the consoles angled so that the controls are just over and in the operators lap accommodating operators of different stature. The ultra compact control pods can be populated with most J.R. Merritt CS, PRO, M, and FS series controllers and (5) 22.5 mm control devices. The versatile design and large choice of options allow the system to fit in numerous applications.

Application:

Commonly used in narrow cabs in excavator shovels, forestry equipment, tower cranes, drills and maintenance of way equipment.

Features

- Full body contoured Grammer Actimo Seat
- Ultra tough nylon velour upholstery
- Adjustable backrest, fore and aft
- Mechanically adjustable lumbar support
- Seat cushion tilt and fore/aft adjustments
- Document pouch
- Single seat and console slide system
- Mechanical 3-step suspension: Full hydraulic and spring dampened system with "Dial in" weight compensation and incremental height adjustment
- Integrated adjustable armrests
- Integrated control pods
- Control arms with manual horizontal, vertical, longitudinal, tilt, and twist adjustments can be flipped back for operator entrance and exit from chair
- Bushing rotator lockable in 10° increments (FSALVDS)
- Ball bearing rotating base (FSALVD)
- Heavy duty steel construction with a powder coat finish

Options:

- Vinyl upholstery
- Adjustable headrest
- Seat belt
- Without suspension
- Mechanical 4-step suspension – 309 lb [140 kg] – 3.2" [80 mm] of height adjustment in 4 increments
- Pneumatic suspension
- 7" fixed open riser
- 7" electrical riser/junction box
- Floor slide for 24" total travel fore and aft or laterally



Model FSALVDS shown with optional adjustable headrest, 7" electrical riser, CS1 joysticks and 22.5 mm control devices.

For detailed information about the seat's benefits, features, and options see Actimo literature.

J.R. MERRITT 
CONTROLS, INC.

Stratford, CT • 1-800-333-JRMC • www.jrmerritt.com

FSALV OVERALL DIMENSIONS Operator Arm Chair System With Fully Adjustable Armrest And Control Consoles

FSALV FIXED

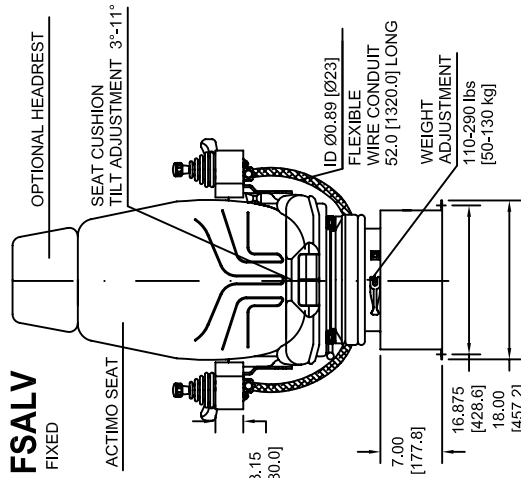

FSALVDS ±90° SWIVEL, LOCKABLE EVERY 10°

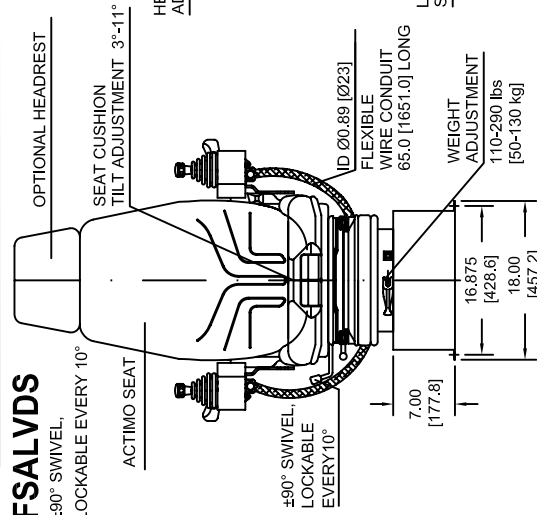

FSALVD BALL BEARING ROTATING BASE

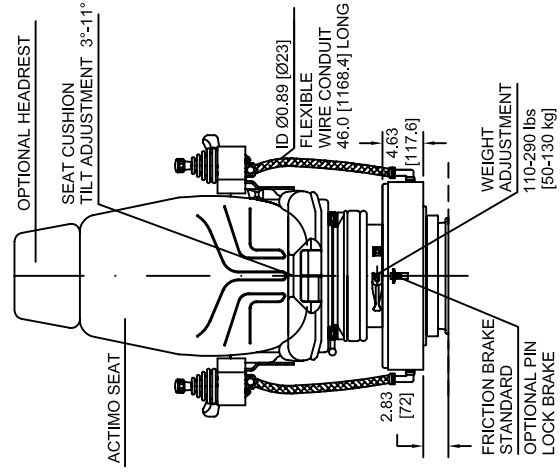
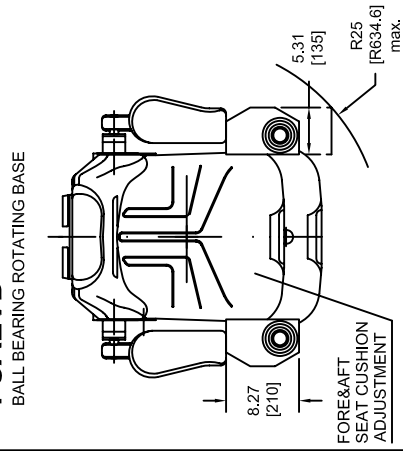

J.R. MERRITT
CONTROLS, INC.

Strafford, CT • 1-800-383-5762 • www.jrmerritt.com