

FSBD

Heavy duty, Rotating Operator Armchair System

Construction:

The **FSBD** is a highly adjustable, compact, heavy duty seating system that integrates seat and controls. This system offers the ultimate of adjustments in a small package. The slim line designed consoles include an integrated ball joint for infinite adjustability, including the ability to be angled so that the controls are just over and in the operators lap. The consoles also include integrated arm pads and can be populated with a variety of J.R. Merritt compact, low cost, rugged controllers along with additional pushbuttons and pilot devices. Three independent slides, additional height and seat tilt adjustments are just some of the additional adjustment features. The versatile design and 270° turning radius allow the system to fit in numerous applications and was developed to accommodate operators of different stature in a variety of cabin configurations. This seating system is very popular for use in port cranes and mining machinery.

Application:

Commonly used on cab operated cranes, container cranes, gantry cranes, straddle carriers, mining dredges, draglines, and shovels.

Features

- Full body contoured Grammer Actimo Seat
- Ultra tough nylon velour upholstery
- Adjustable backrest, fore and aft
- Mechanically adjustable lumbar support
- Seat cushion tilt and fore/aft adjustments
- Document pouch
- Dual acting independent seat slide system
- Independent console slide system with Bowden cable lock
- Mechanical seat scissor for tilt and additional height adjustment
- Mechanical 3-step suspension: Full hydraulic and spring dampened system with "Dial in" weight compensation and incremental height adjustment
- Fixed console mounted arm pads
- Consoles with manual horizontal, vertical, longitudinal, tilt, and slew adjustments
- Pin lock, ball bearing rotating base up to 270°
- Heavy duty steel construction with a powder coat finish

Options

- Vinyl upholstery
- Adjustable Headrest
- Independent height and angular adjustable footrest
- Pneumatic suspension
- Floor slide for 24" total travel fore and aft or laterally
- Wiring and other custom options and accessories available upon request



For detailed information about the seat benefits, features and options see Actimo Literature.

Model FSBD shown with optional headrest, footrest, CS1 controllers and 22.5mm control devices.

J.R. MERRITT 
CONTROLS, INC.

Stratford, CT • 1-800-333-JRMC • www.jrmerritt.com

FSBD

Fully Adjustable Operator Armchair

Approx. Overall Dimensions

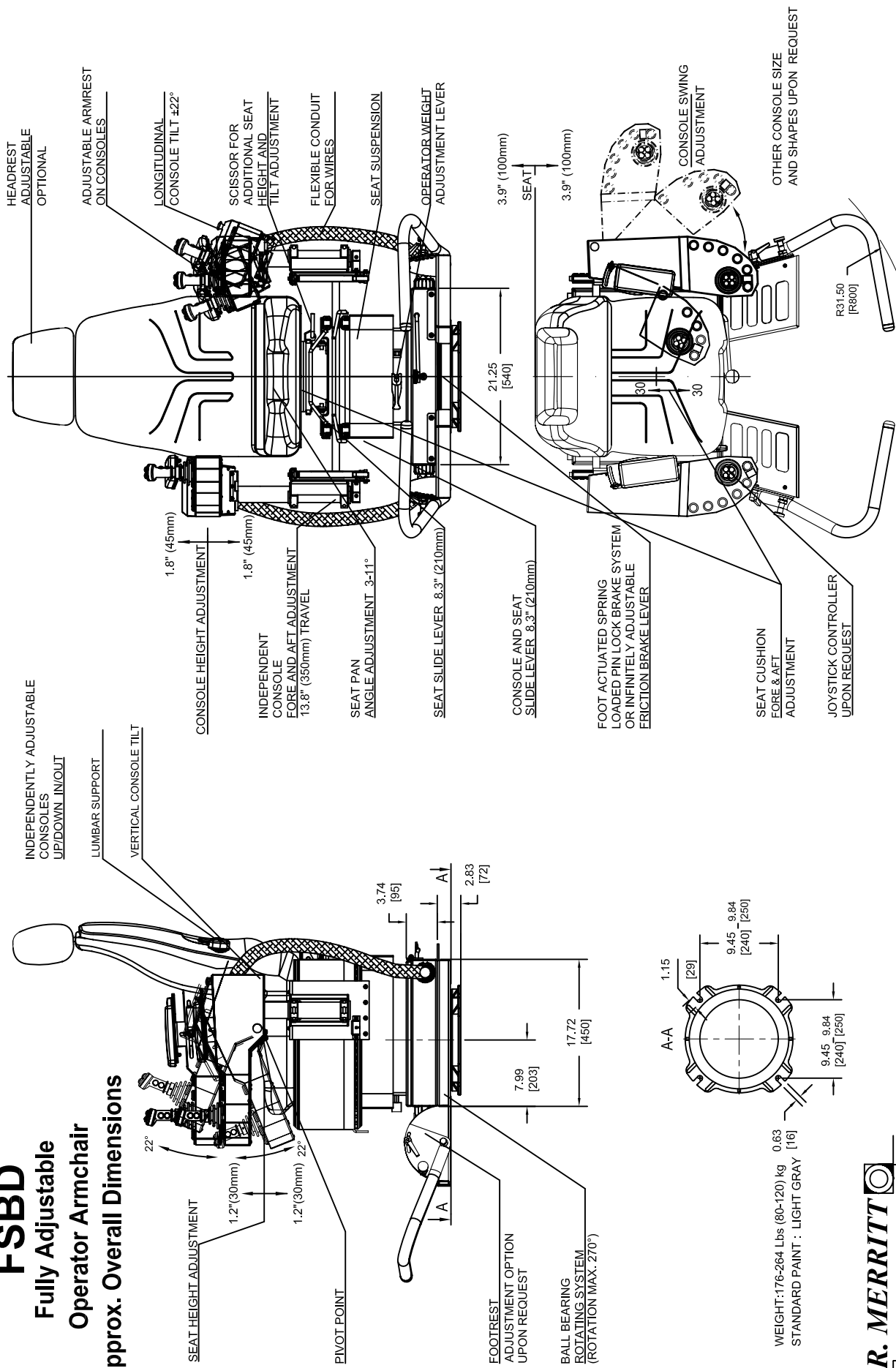

WEIGHT: 176-264 Lbs (80-120) kg 0.63
STANDARD PAINT : LIGHT GRAY [16]



CONTROLS, INC.

Straford, CT • 1-800-333-5762 • www.jrmerritt.com